



TECHNICAL DATA SHEET

airmotive**engineering**CORP.

9503 Middlex | San Antonio, TX 78217
t: 210.820.2450 | f: 210.820.2451 | e: admin@aecorp.aero

AE is recognized for Quality Management System Compliance to ISO 9001:2000.

TDS No.: 06-01

Date Issued: 03/28/2006

Revision: 3 (07/10/09)

Page: 1 of 8

Cold Induction System

- 1.0 **Subject:** Airmotive Engineering (AE) Cold Induction System
- 2.0 **Availability:** The AE Cold Induction Systems are sold through Engine Components Inc. (ECi®) under the TITAN® EXP™ brand.
- 3.0 **Part Numbers and Description:** AE111-1 (Finned sump) and AE111-2 (Unfinned sump)
- 4.0 **General Description:** An EXPERIMENTAL cold induction system for 4 cylinder opposed engines which are based on the Lycoming 320/360 cu. in. design. The AE Cold Induction System consists of an oil sump assembly with “wings” on each side to minimize depth, an induction housing with a forward facing mounting pad for the throttle body/servo and intake pipe assemblies which together increase engine horsepower with no weight penalty when used in conjunction with a fuel injection system. The system has two sump options: 1) The finned sump for optimum oil cooling and, 2) The unfinned sump if cowling clearance below the engine is limited.

WARNING

The AE Cold Induction System is NOT recommended for use with a carburetor. Vertical mount carburetors will not function if mounted directly to the induction plenum, and ECi has not tested the cold induction system with a horizontally mount carburetor or a vertical mount carburetor with transition ducting. ECi believes that a carburetor will be more effective on a Lycoming engine using the standard type sump where the heat from the engine oil helps vaporize the fuel air mixture from the carburetor.

DANGER

If the AE Cold Induction System is retrofitted to an engine that had an aluminum sump in combination with a carburetor or servo fuel injection system, recalculate the weight and balance prior to flying the airplane. A change in weight and balance could cause instability of the aircraft.

- 5.0 **Engine Applications:** Call for information regarding other applications

- ECi TITAN® EXP™ IOX-340S (Stroker) Series
- ECi TITAN® EXP™ IOX-360 Series

- 6.0 **Cold Induction System Schematic:** The Cold Induction System components and their assembly are shown in Figures 1, 2 and 3 which are included in Section 13.0 below.

- 7.0 **Safety Information:** The following special attention notices are used in this Technical Data Sheet to notify and advise the installer and user of the product that certain actions or procedures may be dangerous to the user or result in damage to the product.

NOTE

Notes are used to notify of installation, operation or maintenance information that is important but not safety related.

CAUTION

Caution is used to indicate the presence of a hazard which will or can cause minor injury or property damage if the notice is ignored.

WARNING

Warning advises that a potential hazard exists and denotes actions and procedures that must be followed exactly to either eliminate or reduce the hazard and to avoid serious personal injury or prevent future safety problems with the product.

DANGER

Danger is used to indicate the presence of a hazard that will result in severe personal injury, death or property damage if the notice is ignored.

Cold Induction System

TDS No.: 06-01

Issued Date: 03/28/2006 Rev. 3 (07/10/09)

Page 2 of 8

8.0 Component Description and Installation Instructions**8.1 Magnesium Oil Sump Assembly:**

- 8.1.1 **Description:** The AE Cold Induction Oil Sump is manufactured from a special cast magnesium alloy that has high creep and corrosion resistance. Corrosion resistance is further enhanced by subjecting the casting to a state-of-the-art proprietary conversion coating process after finish machining and before attaching hardware such as studs and plugs. The conversion coated surface serves as an excellent paint base, however, if paint is applied it should be as thin as possible so as not to inhibit heat dissipation properties of the sump.

CAUTION

Use care when handling, assembling and installing the magnesium castings that are part of the AE Cold Induction System. Scratching, chipping or otherwise damaging the conversion coated surface of the magnesium casting will compromise the corrosion resistant coating. If severe surface abrasion of the casting is experienced, contact ECI for additional information. The magnesium castings that are part of the Cold Induction System are not designed to be repaired by welding or plugging because such processes would remove the conversion coated protective coating.

- 8.1.2 **Installation Instructions:** Identify Oil Sump Assembly, gasket, nuts, bolts, internal star washers and flat washers. If the AE Cold Induction System is replacing a conventional integral sump/induction system, remove the existing sump and related components.

WARNING

Do not re-use any attaching hardware when retrofitting the AE Cold Induction System to an engine that was originally built with a conventional induction system. Only use the new hardware that is supplied with the AE Cold Induction System. If any internal star washers are removed after initial assembly, they must be discarded and replaced with new parts. If the recipient engine has time on it, verify that the engine is airworthy before installing the AE Cold Induction System. If the recipient engine is newly assembled, verify that the engine is assembled to the point that it is ready to accept the Induction System.

Place gasket on the sump interface surface and position the sump against the crankcase/accessory case. Use sump studs to guide and position the sump. Temporarily secure the assembly with washers and nuts. Install remaining bolts, washers and nuts. NOTE: Gasket interface surfaces must be clean before gasket and sump installation. The use of sealants is not required. Cleaning and scraping interface surfaces of previously operated engines must be accomplished carefully but thoroughly before installing the sump.

CAUTION

Insure that a flat washer is inserted between the head of the bolt and the crankcase/accessory case and that a flat washer is inserted between the sump casting and the internal star washer which lies underneath the nut. This applies to all attaching hardware used with the AE Cold Induction System. See Figure 3.

WARNING

All fasteners that are to be torqued e.g. studs, bolts, screws, etc. must have a suitable lubricant, e.g. clean 50W engine oil, applied to the threaded area before assembly. Failure to follow this procedure will result in erroneous torque values and may subject the fastener and mating component to premature failure.

After applying a suitable lubricant to the thread on the bolt/stud, torque to inch lbs. listed in System Assembly Parts List table (section 13.2).

8.2 Magnesium Induction Housing:

- 8.2.1 **Description:** Like the oil sump, the AE cold induction housing is also made from a special cast magnesium alloy that has high creep and corrosion resistance. The casting is also conversion coated after machining.

- 8.2.2 **Installation Instructions:** Identify induction housing, spacers, screws and washers. Position induction housing to sump with spacers separating sump and housing and install screws. Torque screws to inch lbs. listed in System Assembly Parts List table (section 13.2). Lockwire screws to the induction housing at each of the four locations.

Cold Induction System

TDS No.: 06-01

Issued Date: 03/28/2006 Rev. 3 (07/10/09)

Page 3 of 8

8.3 Intake Pipe Assemblies:

8.3.1 Description: The AE intake pipes are stainless steel which makes them corrosion resistant and gives them a classic look. The hose connectors are custom molded silicone rubber with a large end and a small end. The large end mates with the induction housing and the small end mates with the intake pipes. The hoses are secured to the mating part by stainless steel worm-type hose clamps. The flanges, gaskets and hardware to connect the intake pipes to the intake port of the cylinder are of conventional design.

8.3.2 Installation Instructions: Identify intake pipes, hoses, clamps, flanges, bolts, flat washers and internal star washers. Slip flanges onto intake pipes. Install hoses on intake pipe ends and secure with hose clamp (do not tighten). Loosely secure intake pipes to cylinder heads with intake pipe flanges, gaskets, bolts and washers. Slip intake pipe open hose ends onto the induction housing outlets and secure with hose clamps (do not tighten). With intake pipes positioned at the cylinder head and the induction housing, proceed to tighten the intake pipe flanges using caution not to reposition the hose ends. Torque the intake pipe flange bolts (lubricated prior to assembly) and the hose clamps to inch lbs. listed in System Assembly Parts List table (section 13.2).

8.4 Inspection: Inspect all interfaces for alignment. Inspect all fasteners (bolts, nuts, washers, clamps and lockwire for proper installation. Re-check all fasteners for proper torque value.

9.0 Disassembly

NOTE: The following order of disassembly and removal is suggested

9.1 Oil: Drain oil from the engine and dispose in an environmentally acceptable way.

9.2 Intake Pipe Assemblies: Loosen and remove the cap screws that attach the intake pipe flange to the cylinder intake port face. Loosen hose clamps and slide the hoses onto the pipe thereby allowing the pipe and hose to be removed from the induction housing. Mark the intake pipes as they are removed from the engine so they can be reassembled in the same location from which they were removed.

9.3 Fuel Injector Throttle Body/Servo: Next, remove the fuel injector throttle body or servo. Remove all potential sources of ignition for any spilled fuel prior to disconnecting fuel lines. Plug or cap all fluid lines and fittings.

9.4 Induction Housing: Remove the induction housing from the bottom of the sump by removing the lockwire from the attaching bolts and unscrewing the bolts. Protect the housing from physical damage.

9.5 Oil Suction Screen: Unscrew the hex head plug. Remove crush-washer (annular) gasket and oil suction screen. Discard crush-washer.

9.6 Oil Sump: Prior to removing the oil sump, ensure that the oil has been completely drained from the engine by removing the two oil drain plugs (1/2" NPT sq. hd. plugs located at the bottom of each "wing"). Remove the fasteners from the periphery of the oil sump and remove the sump from the crankcase/accessory case assembly. Discard gasket.

10.0 Cleaning

10.1 Equipment, materials and processes generally found in engine overhaul facilities are satisfactory for cleaning ferrous and stainless steel parts.

10.2 Magnesium alloy castings should be cleaned by using a combination of an aqueous oil and carbon remover, specifically designed for magnesium, followed by a water rinse and finally, blasting with plastic media. ELDORADO HT-2220A, a product of Eldorado Chemical Company Inc., removes oil, grease, carbon and most paints (powder coatings excepted). Gasket material will have to be carefully removed by scraping. Blasting with plastic media after chemical cleaning and scraping leaves a surface that can be inspected for cracks.

11.0 Inspection

11.1 Intake pipes: Visually inspect for dents and cracks. No dents or cracks are allowed. Insure that the face of the flanged end is square and flat with no nicks.

11.2 Induction Housing and Oil Sump: In addition to visual inspection, magnesium alloy castings should undergo liquid penetrant inspection to

Cold Induction System

TDS No.: 06-01

Issued Date: 03/28/2006 Rev. 3 (07/10/09)

Page 4 of 8

detect possible cracks. Either visible dye or fluorescent penetrant methods may be employed according to standard procedures for these processes. Structural cracks are cause for rejection.

11.3 Oil Pick-up Screen: Clean and inspect for damage to screen. Discard if damaged.

11.3 Hose Connections: Visually inspect hose material for deterioration, fuel and/or oil intrusion and general condition. Reuse or replace as necessary.

12.0 **Reassembly**

12.1 Oil Sump and Induction Housing: Prior to reassembly, if there is evidence that the conversion coating has been extensively compromised, immerse the thoroughly cleaned casting in a hot dichromate solution (3/4 lb. of sodium dichromate to one gallon of water at 180°F to 200°F) for 45 minutes. Wash immediately in clean room temperature water followed by immersion in hot water followed by an air blast to dry. Immediately apply a zinc chromate paint primer (AMS3110 or equivalent) to the damaged surfaces followed by high quality engine enamel. Allow adequate time for curing as prescribed by the paint manufacturer before reassembling on the engine using installation procedures defined in Paragraph 8.0 above. If the damaged area is small, the sodium dichromate process may be eliminated.

12.2 Oil Sump Assembly: Assemble attaching parts to the oil sump. The following parts may be reused:

- Oil pick-up screen
- Oil pick-up screen cover (replace crush washer)
- Oil drain plugs or quick drains

12.3 Intake pipe assemblies: Identify all necessary parts and insure that they pass the inspection criteria contained in this TDS. Install pipe assemblies on the engine using installation procedures defined in Paragraph 8.0 above. Use new gaskets and hardware which are available in kits and which are listed in the Illustrated Parts section of this TDS, Paragraph 13.0.

Cold Induction System

TDS No.: 06-01

Issued Date: 03/28/2006 Rev. 3 (07/10/09)

Page 5 of 8

13.0 **Illustrated Parts List**

13.1 **Illustrations:** (3)

Figure 1. Sump Assembly
AE14002-1 & -2*

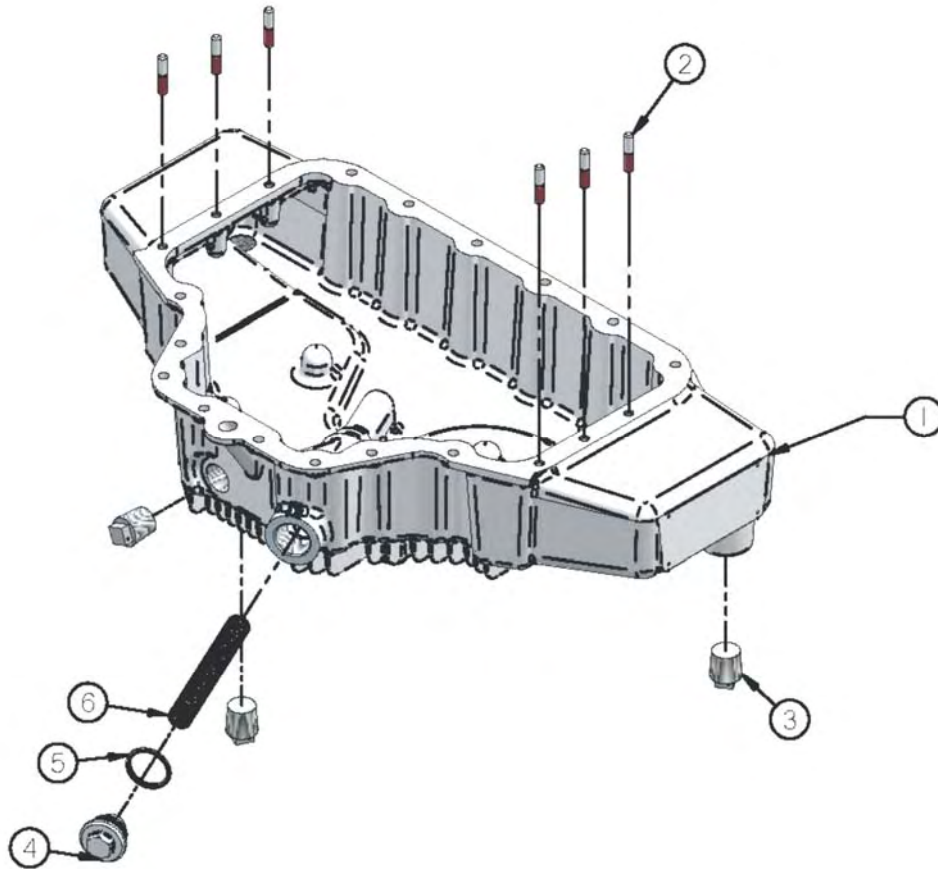

*Sump without fins

Cold Induction System

TDS No.: 06-01

Issued Date: 03/28/2006 Rev. 3 (07/10/09)

Page 6 of 8

Figure 2. Plenum and Intake Pipe Assembly

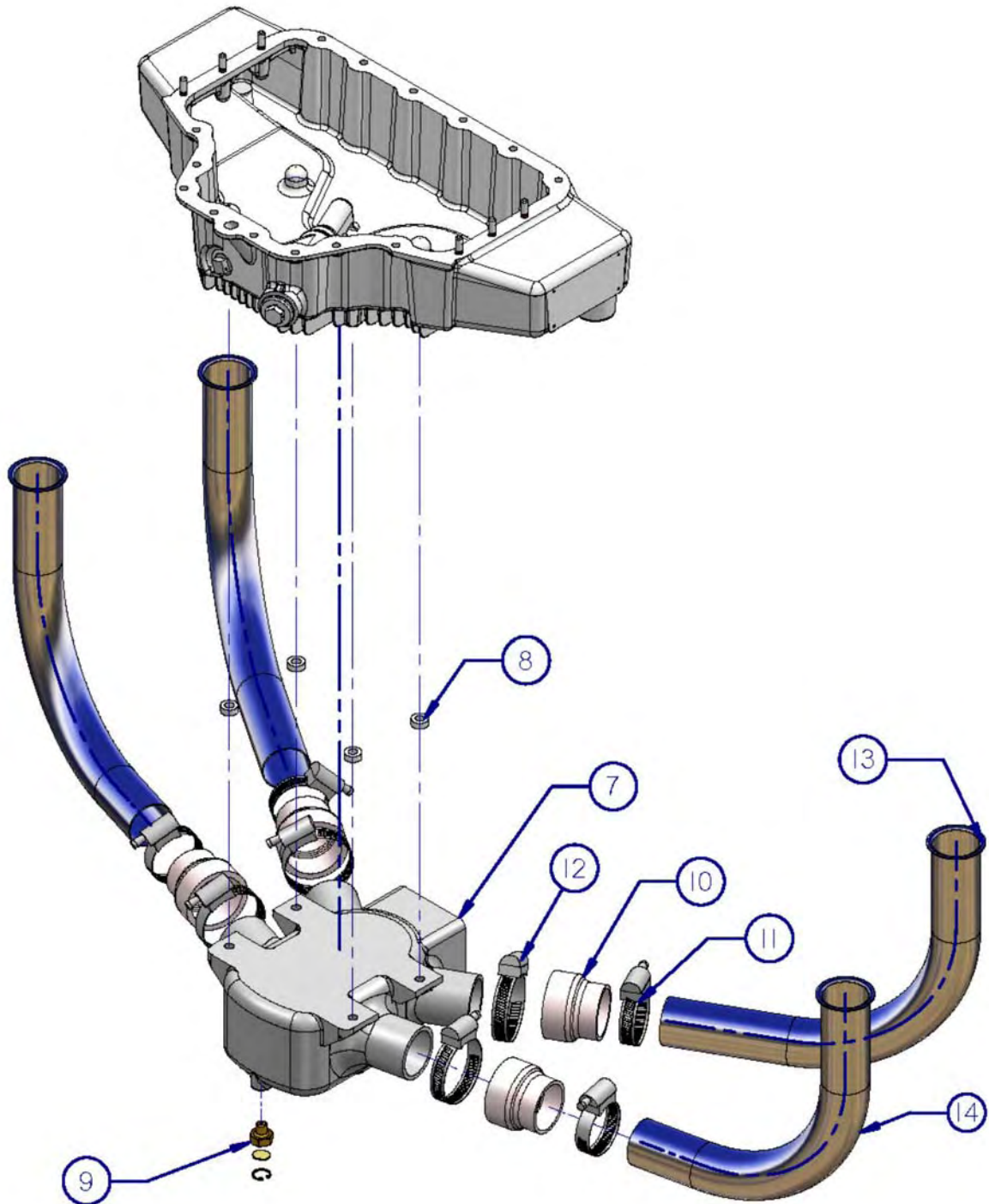

Cold Induction System

TDS No.: 06-01

Issued Date: 03/28/2006 Rev. 3 (07/10/09)

Page 7 of 8

Figure 3. System Assembly

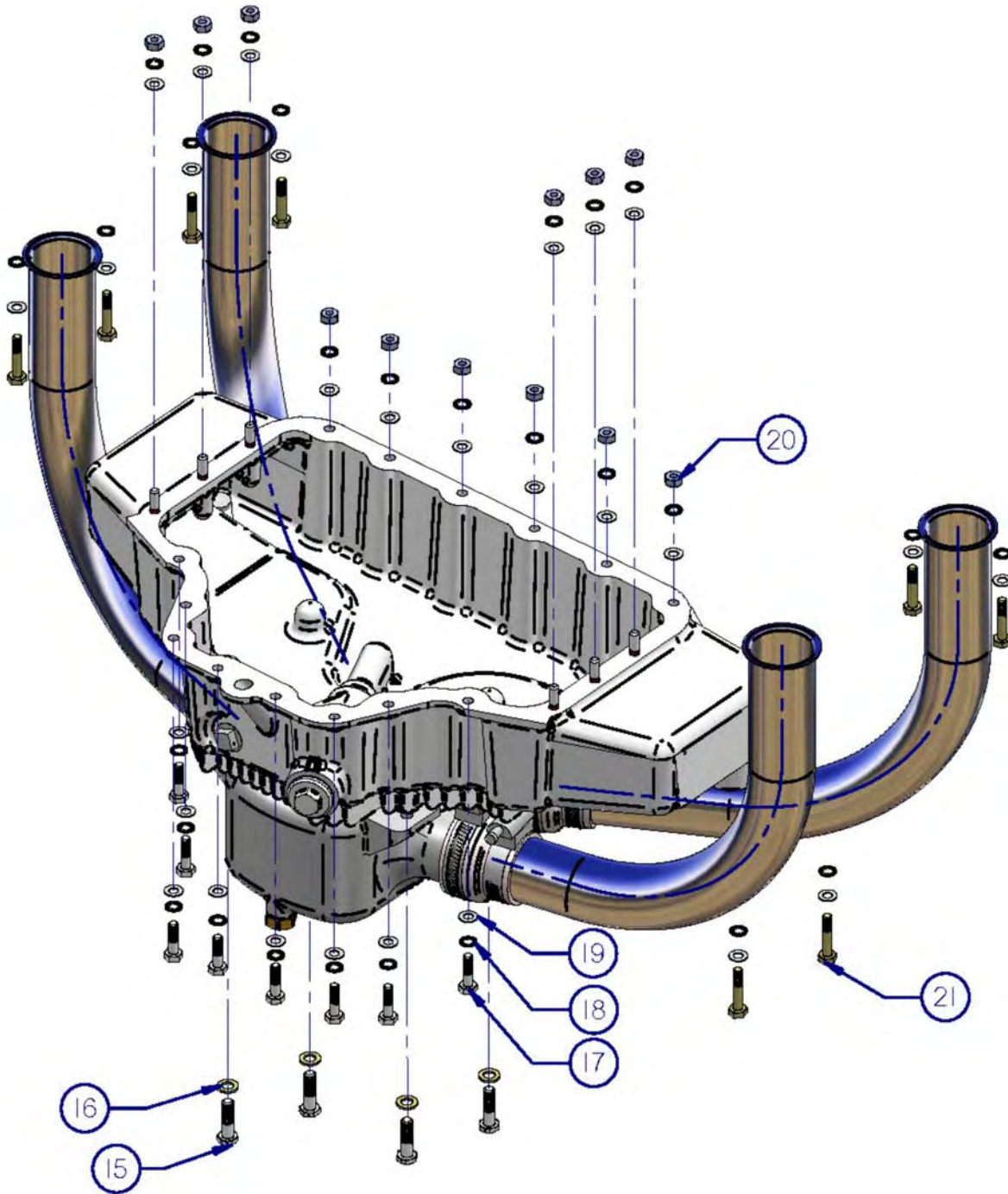

Cold Induction System

TDS No.: 06-01

Issued Date: 03/28/2006 Rev. 3 (07/10/09)

Page 8 of 8

13.2 Parts List

System Assembly Parts List

Item No.	Part Number	Description	Qty.	Torque (in.-lbs.)
1	AE14001-1	Machining, Oil Sump (Finned)	1	-
1	AE14001-2	Machining, Oil Sump (UnFinned)	1	-
2	AEL61400	Stud, 1/4-20 x 1-3/16 Long	6	15
3	AELSTD551	Plug, Pipe, 1/2-14 NPT	3	160
4	AEL12545	Plug, Oil Screen	1	*
5	AELSTD111	Gasket, 1.0 ID x 1-1/4 OD	1	-
6	AEL70484	Screen, Oil Suction	1	-
7	AE30025-1	Plenum, Machining (Straight)	1	-
7	AE30025-2	Plenum, Machining (7° Downward)	1	-
7	AE30025-3	Plenum, Machining (7° Upward)	1	-
8	AE30007-06	Packing, Plenum (.06 thk.)	4	-
8	AE30007-25	Packing, Plenum (.25 thk)	4	-
9	AE100064	Assembly, Drain Valve	1	40
10	AE30026	Hose	4	-
11	NAS1924-74	Clamp, Hose	4	45
12	NAS1924-82	Clamp, Hose	4	45
13	AE30020	Pipe, Intake (360 Finned)	2	-
13	AE30028	Pipe, Intake (320/340S Finned)	2	-
13	AE30035	Pipe, Intake (360 Unfinned)	2	-
13	AE30037	Pipe, Intake (320/340S Unfinned)	2	-
14	AE30021	Pipe, Intake (360 Finned)	2	-
14	AE30029	Pipe, Intake (320/340S Finned)	2	-
14	AE30036	Pipe, Intake (360 Unfinned)	2	-
14	AE30038	Pipe, Intake (320/340S Unfinned)	2	-
15	AE8001H5-1.13	Bolt, 5/16-18 UNC x 1-1/8 Long	4	204**
16	AE51412-5	Washer, Plain, 5/16	4	-
17	AE8001-4-1.00	Bolt, Hex. 1/4-20 UNC x 1.00 Long	14	96
18	AE51413-4	Washer, Internal Lock, 5/16	28	-
19	AE51412-4	Washer, Plain, 1/4	34	-
20	AE9885-4	Nut, 1/4-20 UNC	12	96
21	AE8001-4-1.25	Bolt, Hex. 1/4-20 UNC x 1-1/4 Long	8	96

* 135° after full contact

** Lockwire to casting